

Notes:

1. Drawing Shown With Traffic Rated Lid, Concrete Risers & Traffic Rated Castings
2. Non-Traffic Rated Lids And Risers Available
3. 12" Concrete Risers Shown, Minimum of 12" Cover to Meet H20 Traffic Rating.
4. Reinforcement Drawings Available Upon Request.
5. Traffic Rated Tank Lids Meet H20 Standard.
6. Internal Plumbing Specified By Customer
7. Inter Plumbing Pre Installation Available

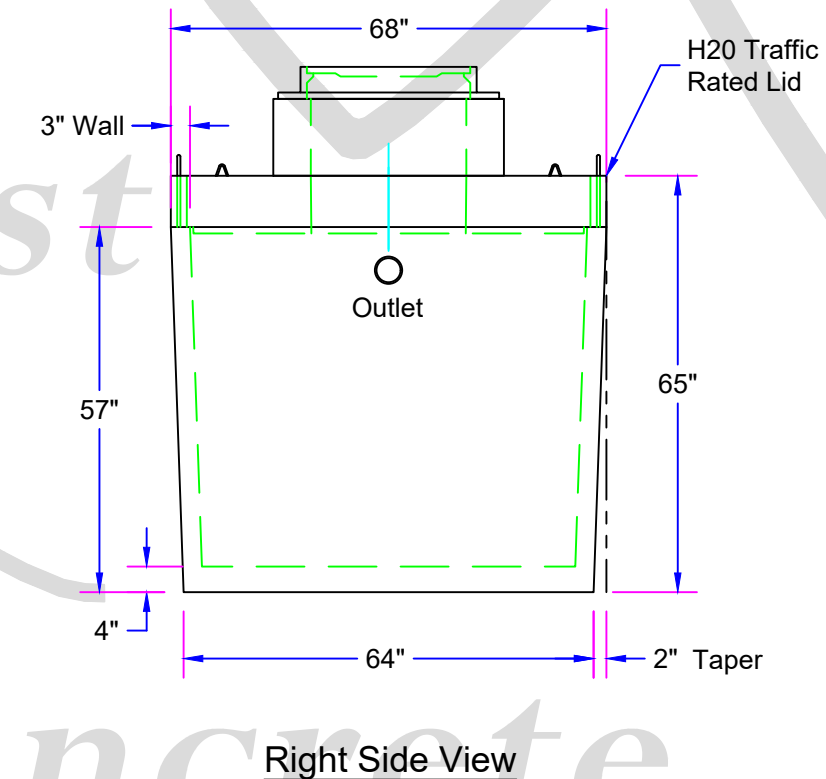
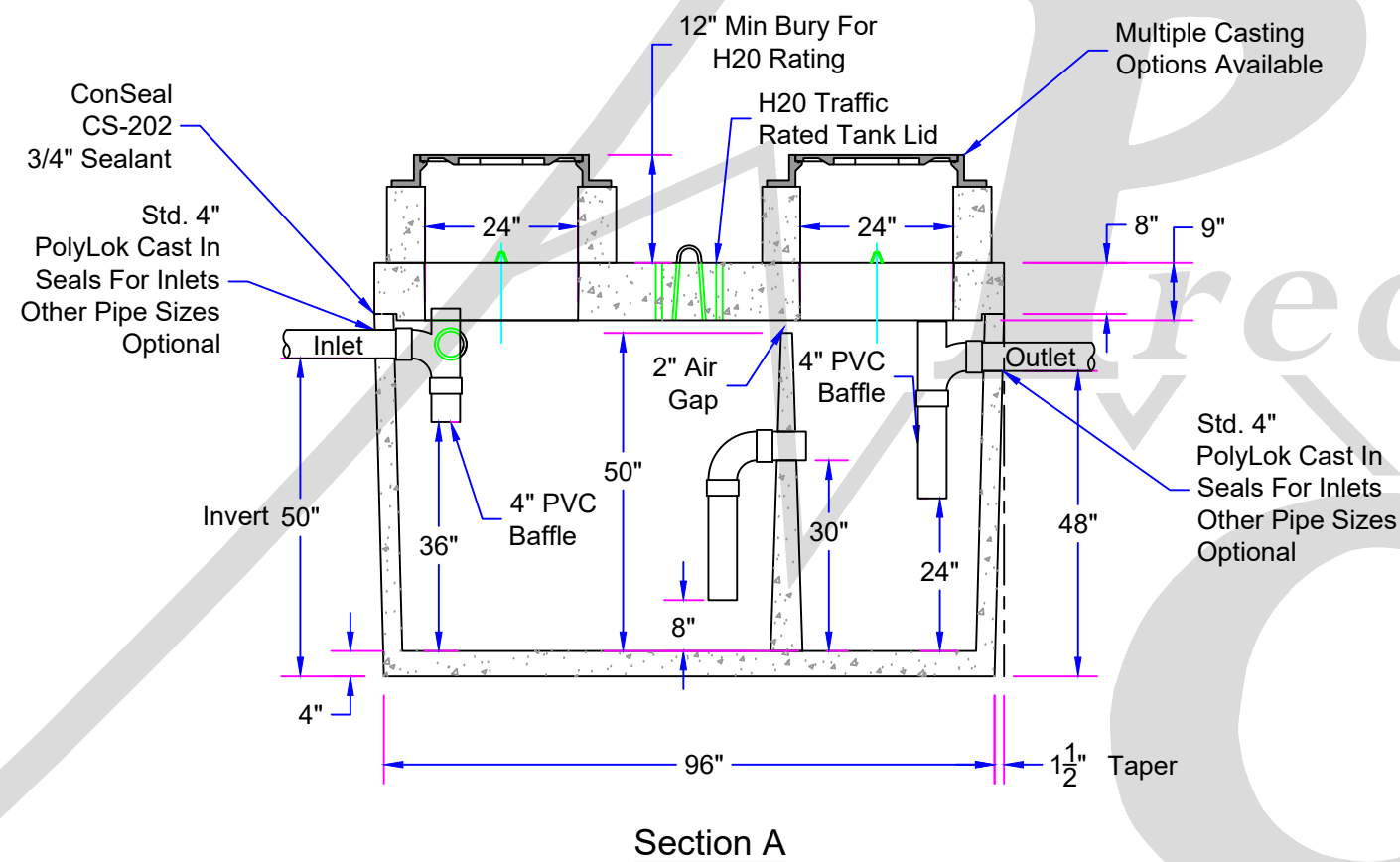

Approx. Weight With Standard Lid = **10,370 Lbs.**  
 Approx. Weight With Traffic Rated Lid = **12,680 Lbs.**

Glacier  
Precast  
Concrete, Inc.



175 Alder Lane  
Kalispell, MT. 59901  
(406) 752-7163  
www.glacierprecast.com  
Or Visit Us On Facebook

AMENDMENTS:			
REV:	DESCRIPTION:	BY:	DATE:

SITE:	Glacier Precast Concrete
TITLE:	1000 Gallon Interceptor/Separator Tank

DRAWING NO.	PROJECT NO.	DATE:
1:30	JRC	2/20/2017
SCALE AT A4.	DRAWN.	CHECKED.
		REVISION.