

Notes:

1. Drawing Shown With Concrete Lids, Concrete Risers and PVC Lids and Risers Available.
2. Reinforcement Drawings Available Upon Request.
3. Tank Designs Meet ASTM C1227, C890 & Montana DEQ Circular 4 With 6 Feet Of Bury.
4. Traffic Rated Tank Lids Available.
5. Minimum 4000 PSI Concrete

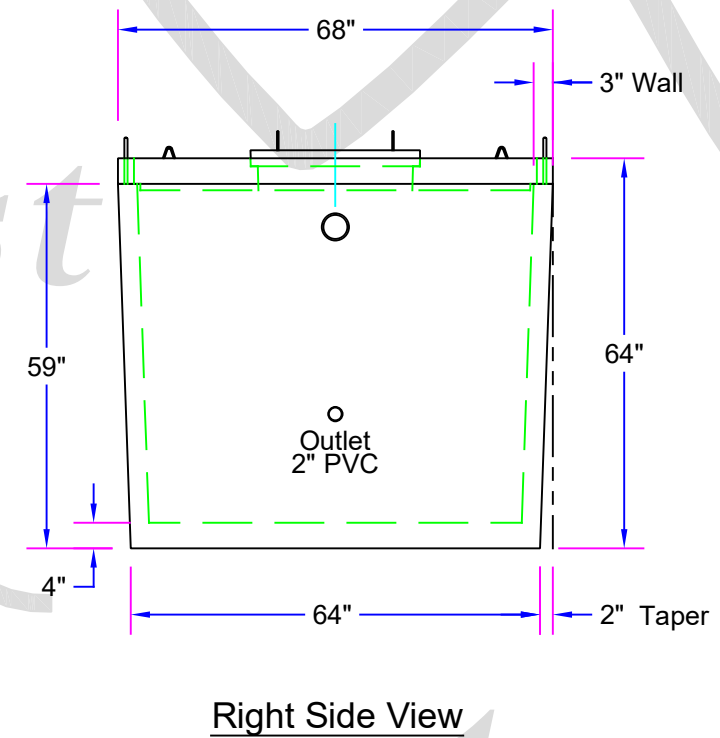
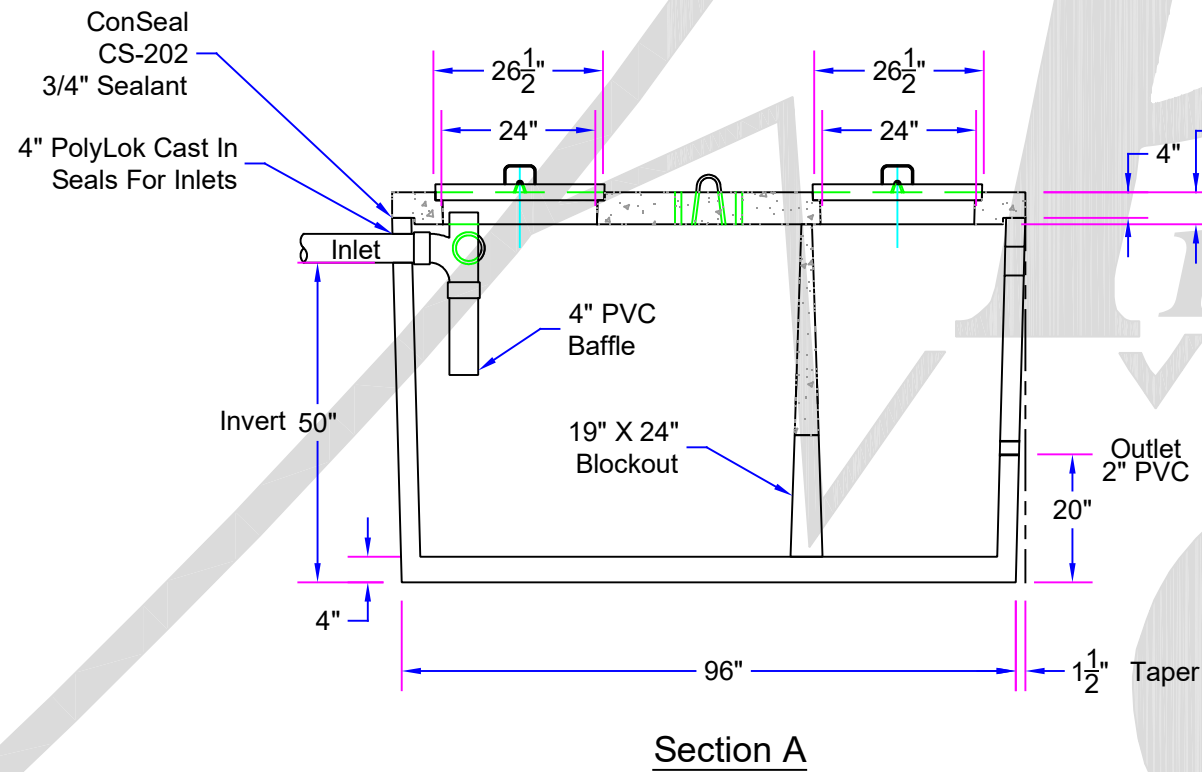

Approx. Weight With Standard Lid = **10,370 Lbs.**
 Approx. Weight With Traffic Rated Lid = **12,680 Lbs.**

Glacier
Precast
Concrete, Inc.



175 Alder Lane
Kalispell, MT. 59901
(406) 752-7163
www.glacierprecast.com
Or Visit Us On Facebook

AMENDMENTS:			
REV.	DESCRIPTION:	BY:	DATE:

SITE:	Glacier Precast Concrete
TITLE:	1000 Gallon Dose Tank

DRAWING NO.	PROJECT NO.	DATE:
1:30	JRC	10/21/20
SCALE AT A4.	DRAWN.	CHECKED.
		REVISION.