

- Notes:
1. Drawing Shown With Concrete Lids, Concrete Risers and PVC Lids and Risers Available.
  2. Reinforcement Drawings Available Upon Request.
  3. Tank Designs Meet ASTM C1227, C890 & Montana DEQ Circular 4 With 6 Feet Of Bury.
  4. Traffic Rated Tank Lids Available.
  5. Minimum 4000 PSI Concrete
  6. New tank dimensions vary slightly H: 64", L: 98", W:68"

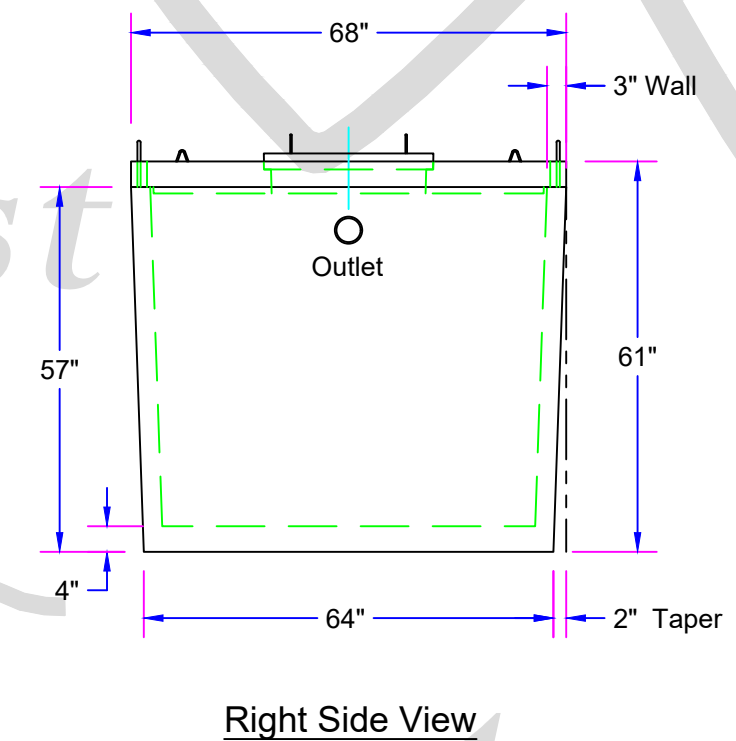

Approx. Weight With Standard Lid = **10,370 Lbs.**  
 Approx. Weight With Traffic Rated Lid = **12,680 Lbs.**

Glacier  
Precast  
Concrete, Inc.

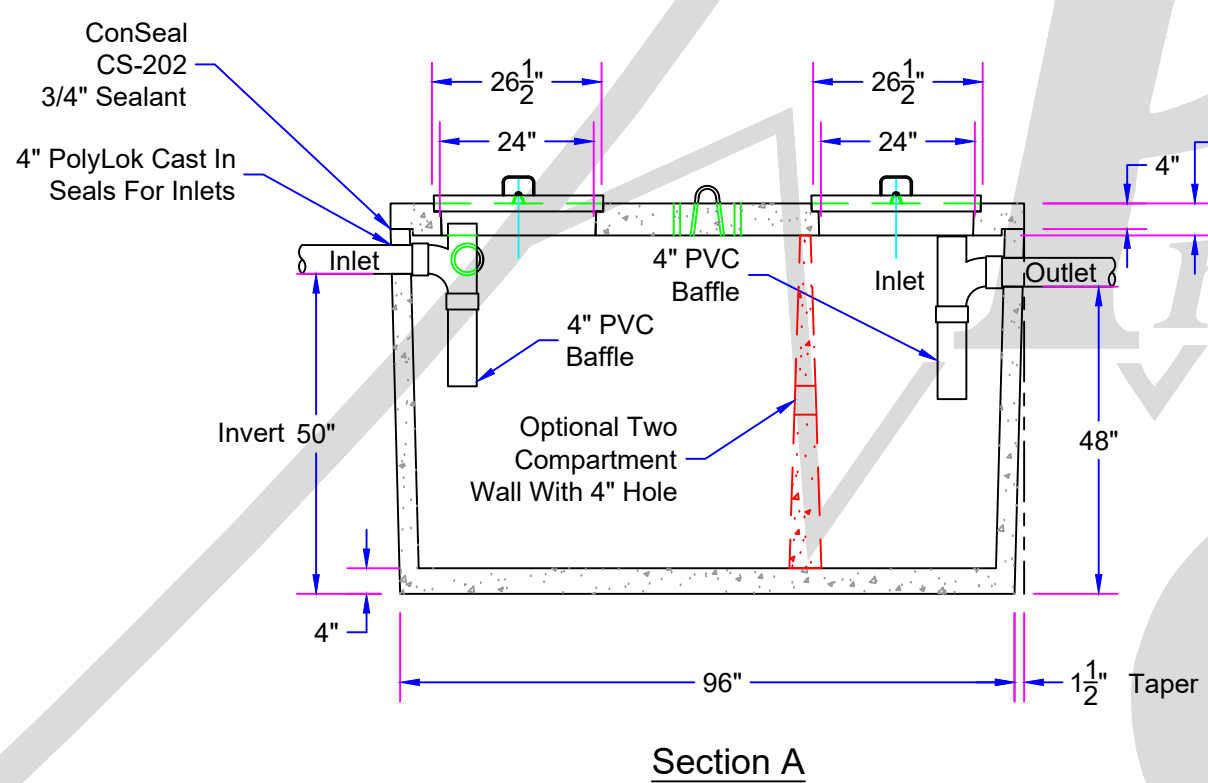

175 Alder Lane  
Kalispell, MT. 59901  
(406) 752-7163  
www.glacierprecast.com  
Or Visit Us On Facebook

AMENDMENTS:			
REV.	DESCRIPTION:	BY:	DATE:

SITE:	Glacier Precast Concrete
TITLE:	1000 Gallon Septic Tank

DRAWING NO.	1:30	PROJECT NO.	2/08/2022
SCALE AT A4.	EJP	CHECKED.	DATE.
DRAWN.		REVISION.	