

Notes:

1. Drawing Shown With Traffic Rated Lid, Concrete Risers & Traffic Rated Castings
2. Non-Traffic Rated Lids And Risers Available
3. 12" Concrete Risers Shown, Minimum of 12" Cover to Meet H2O Traffic Rating.
4. Reinforcement Drawings Available Upon Request.
5. Traffic Rated Tank Lids Meet H2O Standard
6. Internal Plumbing Is Called Out By Customer
7. Inter Plumbing Pre Installation Available

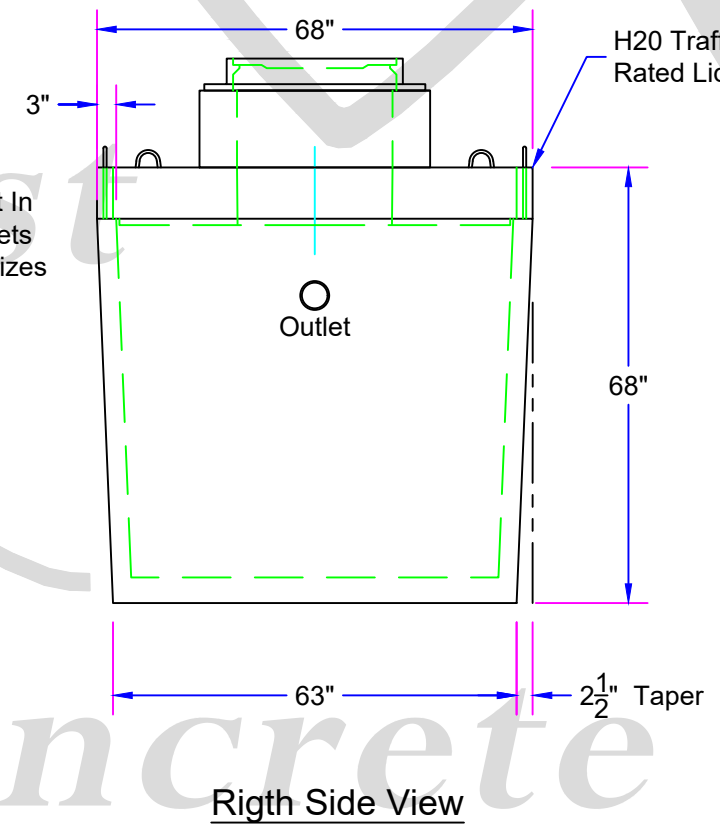
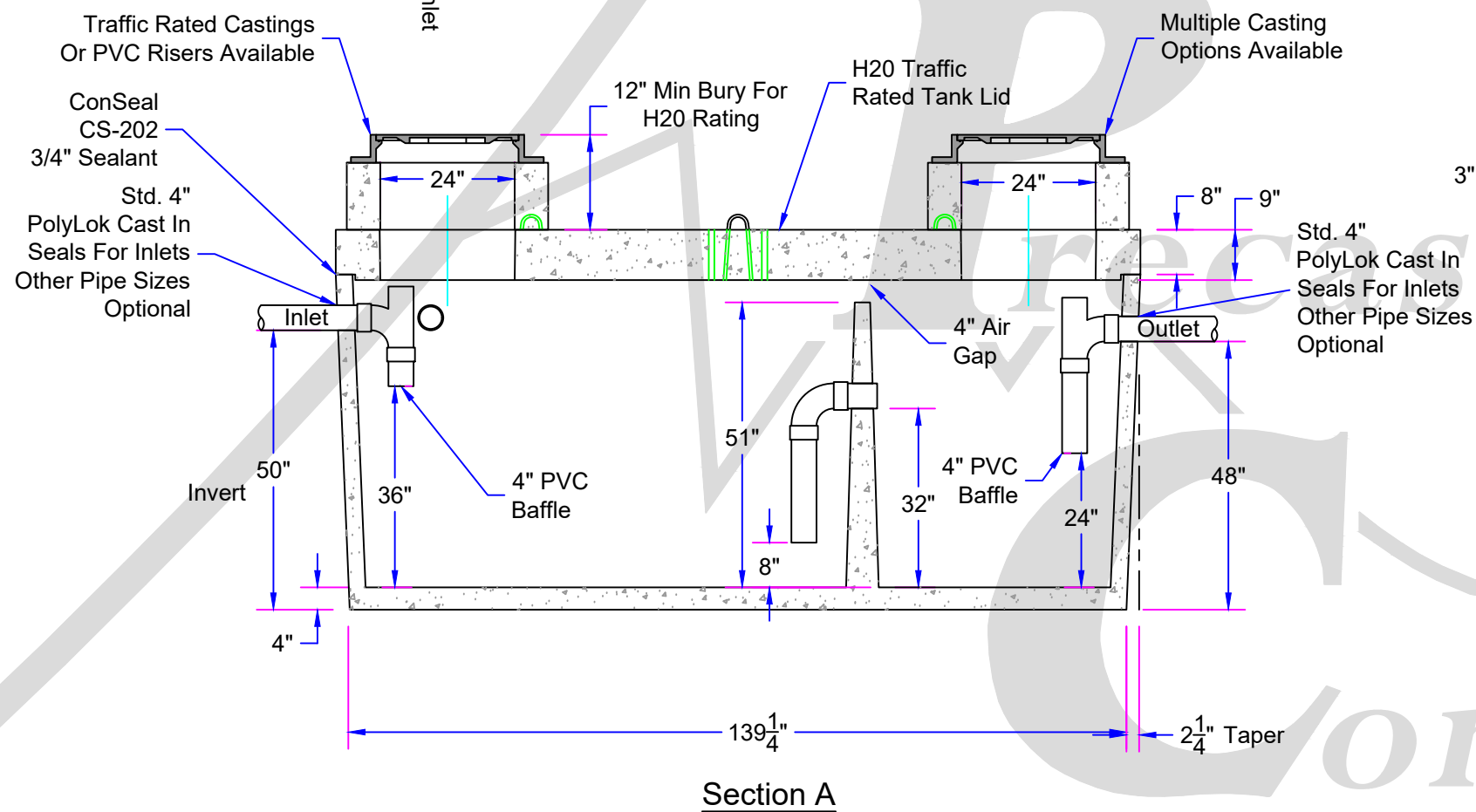

Approx. Weight With Standard Lid = **14,100 Lbs.**
 Approx. Weight With Traffic Rated Lid = **17,100 Lbs**

Glacier
Precast
Concrete, Inc.



175 Alder Lane
Kalispell, MT. 59901
(406) 752-7163
www.glacierprecast.com
Or Visit Us On Facebook

AMENDMENTS:			
REV:	DESCRIPTION:	BY:	DATE:

SITE:	Glacier Precast Concrete, Inc.
TITLE:	1500 Gallon Interceptor/Separator Tank

DRAWING NO.	PROJECT NO.	DATE:
1:30	JRC	02/17/2017
SCALE AT A4.	DRAWN.	CHECKED.
		REVISION.