

- Notes:
1. Drawing Shown With Concrete Lids, Concrete Risers and PVC Lids and Risers Available.
 2. Reinforcement Drawings Available Upon Request.
 3. Tank Designs Meet ASTM C1227, C890 & Montana DEQ Circular 4 With 6 Feet Of Bury.
 4. Traffic Rated Tank Lids & Castings Available.
 5. Minimum 4000 PSI Concrete

ConSeal
CS-202
3/4" Sealant
PolyLok Cast In
Seals For Pipe
Penetrations

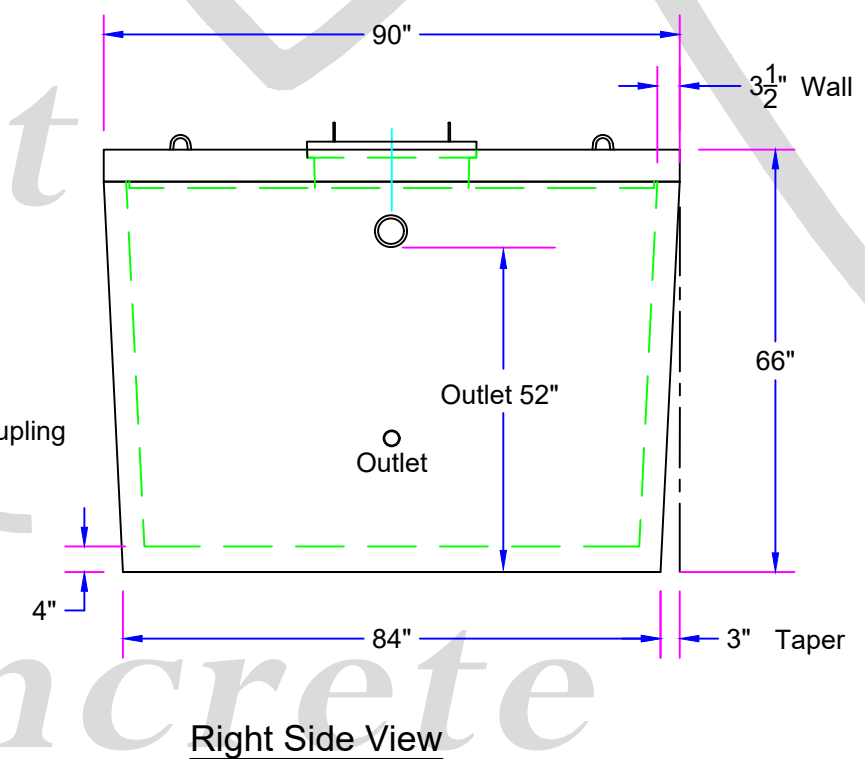
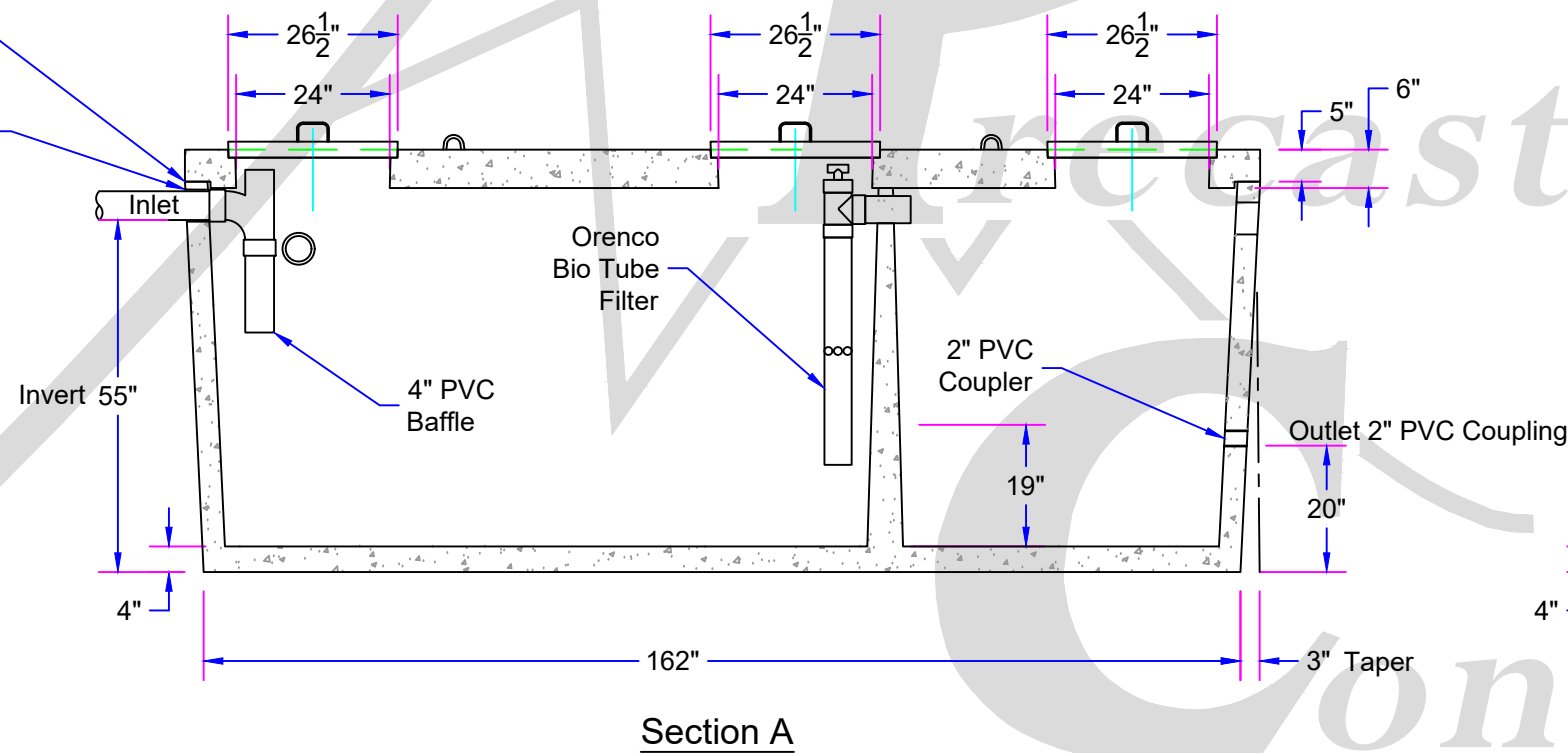

Approx. Weight With Standard Lid = **21,115 Lbs.**
 Approx. Weight With Traffic Rated Lid = **25,630 Lbs.**

Glacier
Precast
Concrete, Inc.



175 Alder Drive
Kalispell, MT. 59901
(406) 752-7163
www.glacierprecast.com
Or Visit Us On Facebook

AMENDMENTS:			
REV:	DESCRIPTION:	BY:	DATE:

SITE:
Glacier Precast Concrete

TITLE:
2500 Gal. 1667 Septic/832 Pump Chamber

DRAWING NO.	PROJECT NO.	DATE:
1:30	EJP	2/08/2022
SCALE AT A4.	DRAWN.	CHECKED.
		REVISION.