

- Notes:
1. Drawing Shown With Concrete Lids, Concrete Risers and PVC Lids and Risers Available.
 2. Reinforcement Drawings Available Upon Request.
 3. Tank Designs Meet ASTM C1227, C890 & Montana DEQ Circular 4 With 6 Feet Of Bury.
 4. Traffic Rated Tank Lids Available.
 5. Minimum 4000 PSI Concrete

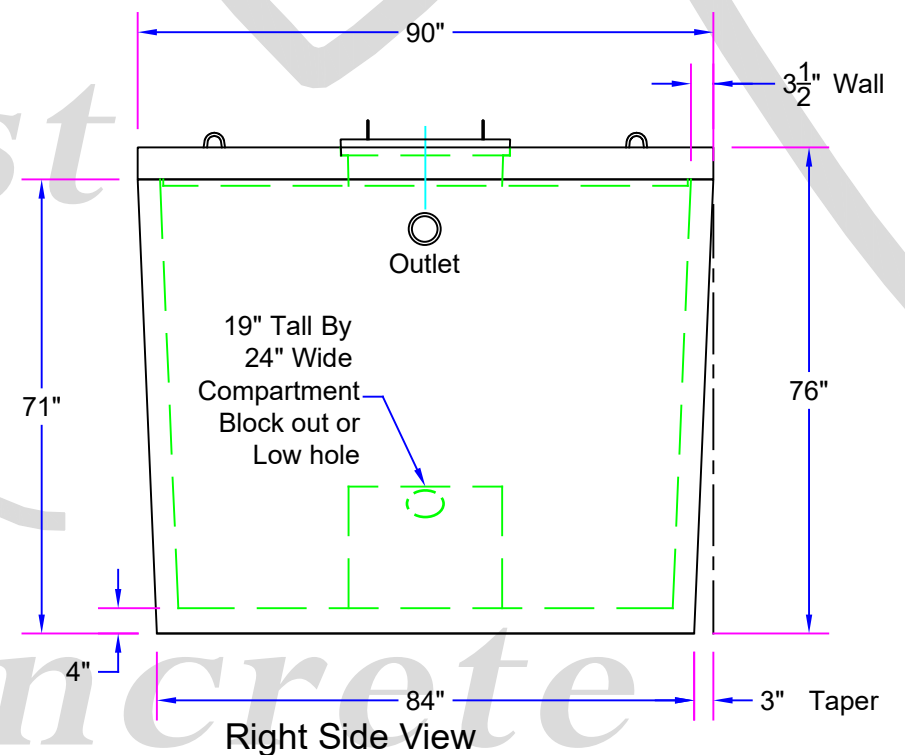

Approx. Weight With Standard Lid = **22,670 Lbs.**
 Approx. Weight With Traffic Rated Lid = **27,190 Lbs.**

Glacier
Precast
Concrete, Inc.

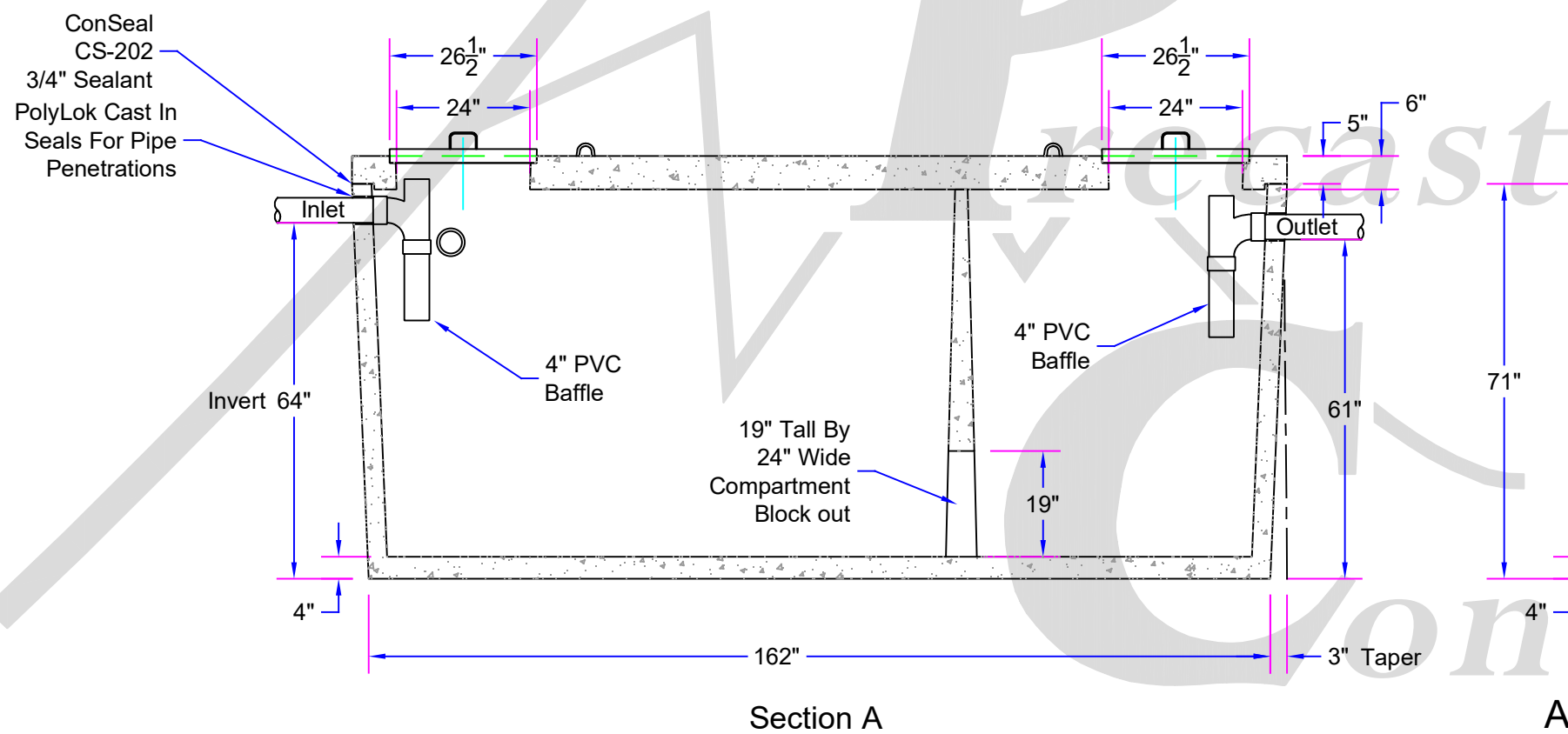

175 Alder Lane
Kalispell, MT. 59901
(406) 752-7163
www.glacierprecast.com
Or Visit Us On Facebook

AMENDMENTS:			
REV:	DESCRIPTION:	BY:	DATE:

SITE: **Glacier Precast Concrete**
 TITLE: **3000 Gallon Septic Tank**

DRAWING NO.	PROJECT NO.	DATE:
1:30	EJP	2/08/2022
SCALE AT A4.	DRAWN.	CHECKED.
		REVISION.