

Dimensions

Face Width 48" 1219mm
 Back Width 39" 991mm
 Depth 24" 610mm
 Height 24" 610mm
 Face Area 8 sq ft 0.74 sq m
 Setback 4.5deg 2.0"/Unit
 Weight 1370lbs 621Kg*

STANDARD UNIT

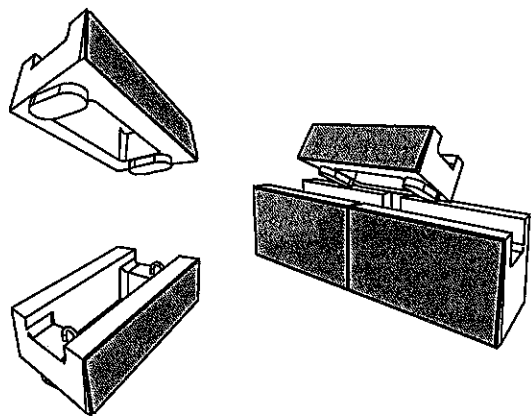

Dimensions

Face Width 48" 1219mm
 Back Width 39" 991mm
 Depth 24" 610mm
 Height 12" 305mm
 Face Area 4 sq ft 0.37sq m
 Setback 4.5deg 1.0"/Unit
 Weight 750lbs 340Kg*

HALF HIGH UNIT

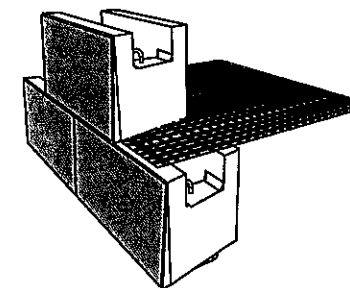

GEOGRID PLACED FLAT AND TAUGHT FOR MAXIMUM SECURE LUG CONNECTION

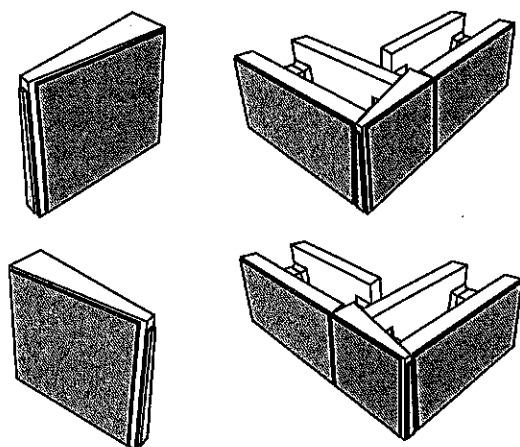

Dimensions

Face Width 26" 660mm
 Back Width 26" 660mm
 Depth 3/8.5" 76/215mm
 Height 24" 610mm
 Face Area 4.3sq ft 0.4 sq m
 Setback 4.5deg 2"/Unit
 Weight 314lbs 142Kg*

CORNER/END UNIT

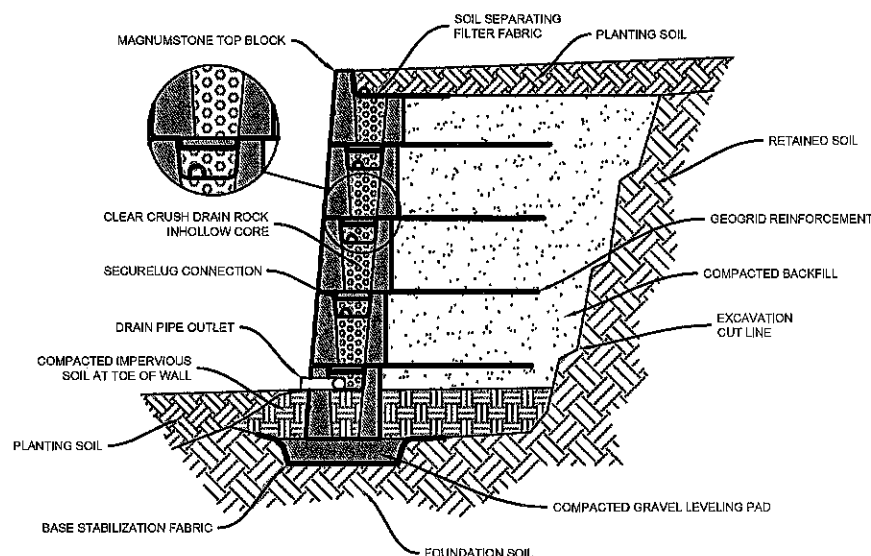

GEOGRID REINFORCED WALL

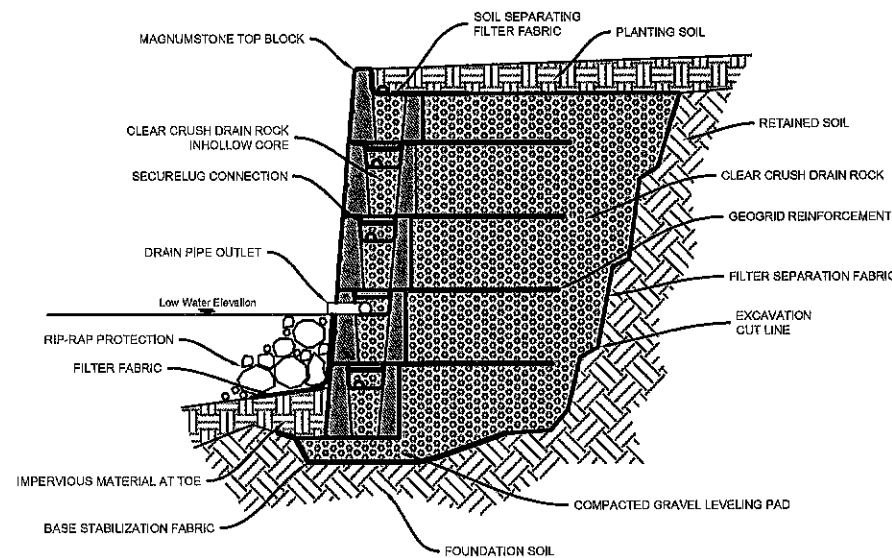

WATER APPLICATION

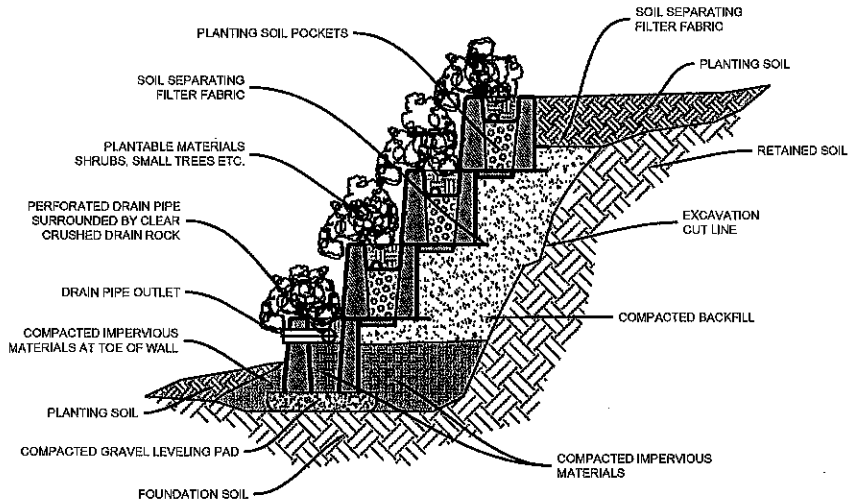

2.0 FT PLANTABLE WALL

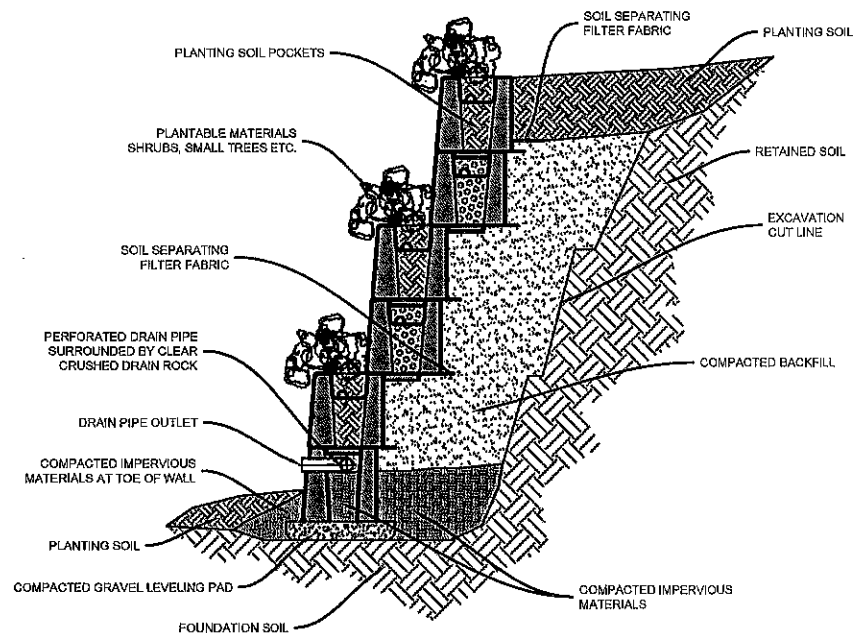

4.0 FT PLANTABLE WALL

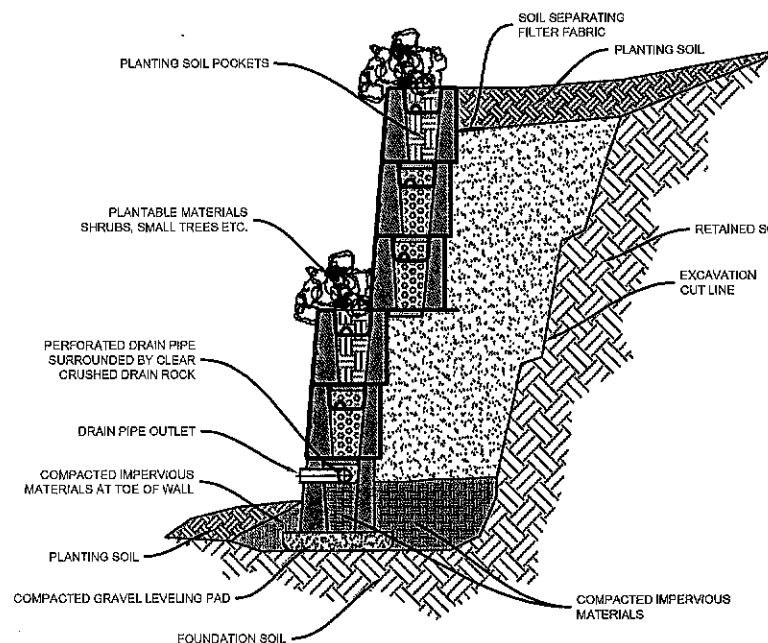

6.0 FT PLANTABLE WALL

General Notes

No.	Revision/Issue	Date

MagnumStone™
 by CORNERSTONE®

Project Name and Address

Project

Sheet

Date

Block

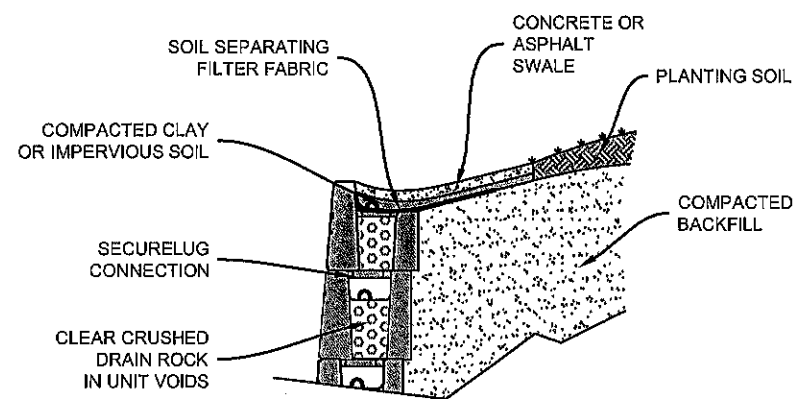

CONCRETE / ASPHALT SWALE

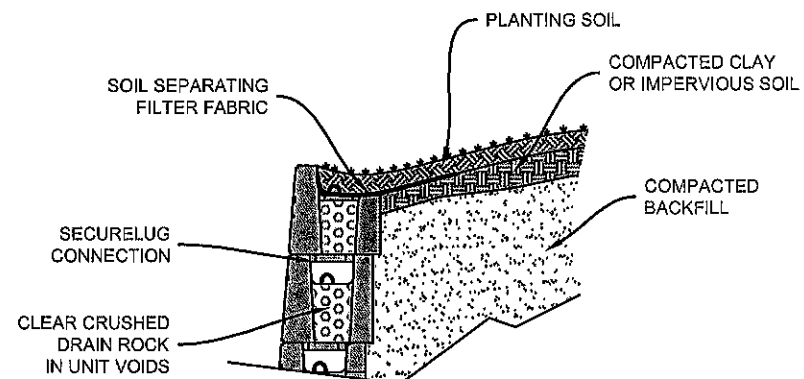

CLAY / IMPERVIOUS SWALE

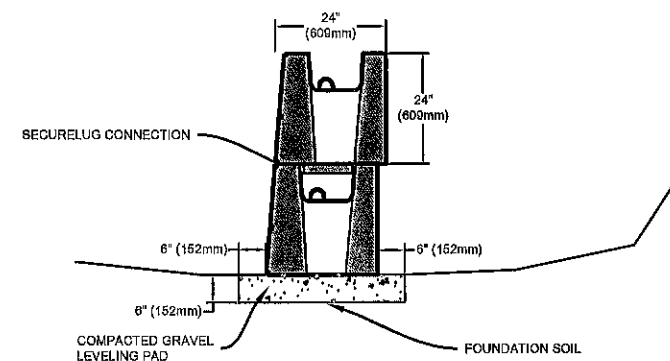

LEVELING PAD

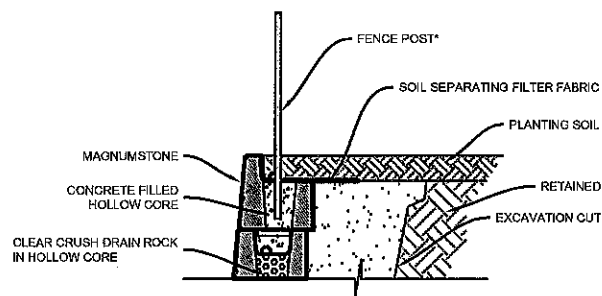

FENCE THROUGH HOLLOW CORE

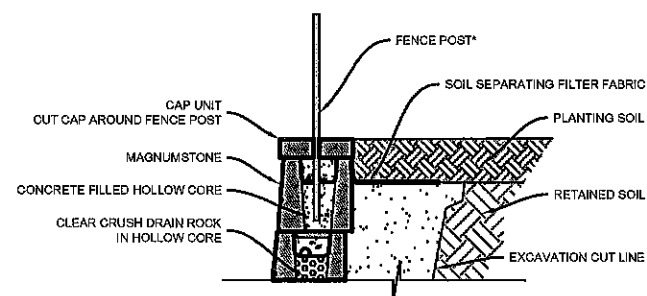

FENCE THROUGH HOLLOW CORE W /CAP

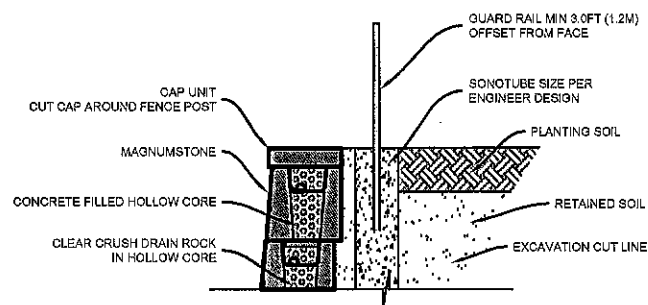

GUARD RAIL

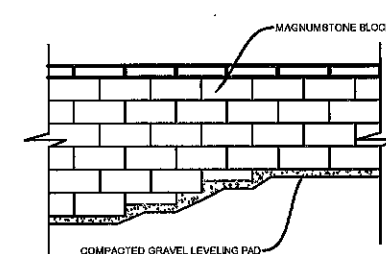

BASE STEP UP

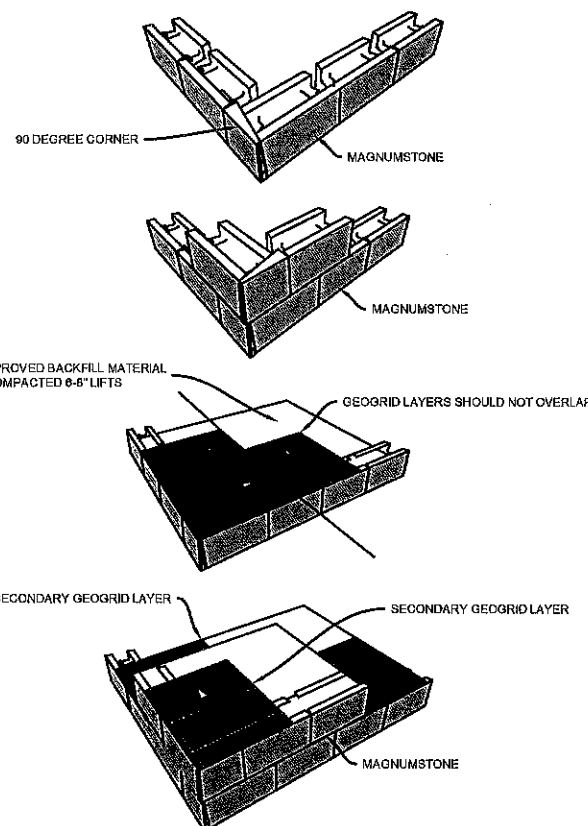

OUTSIDE CORNER

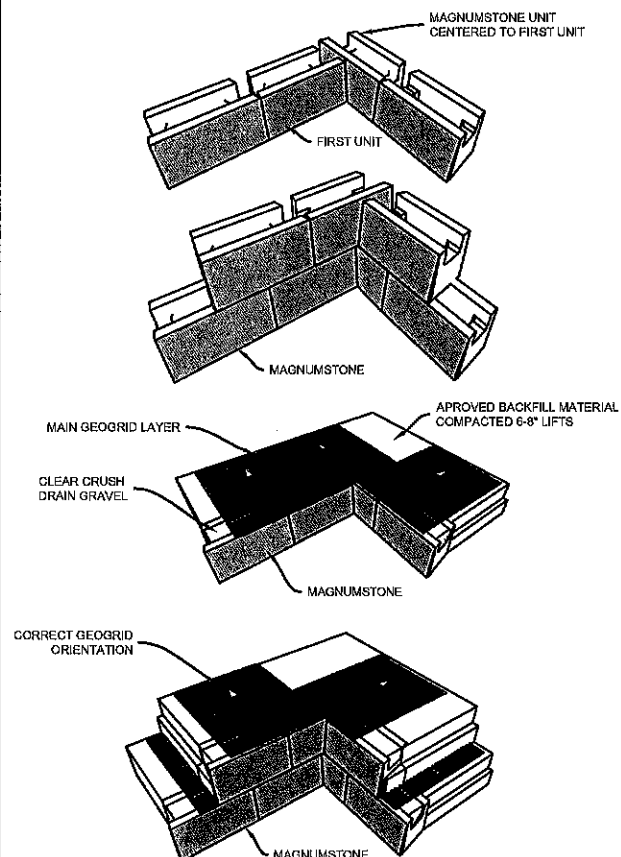

INSIDE CORNER

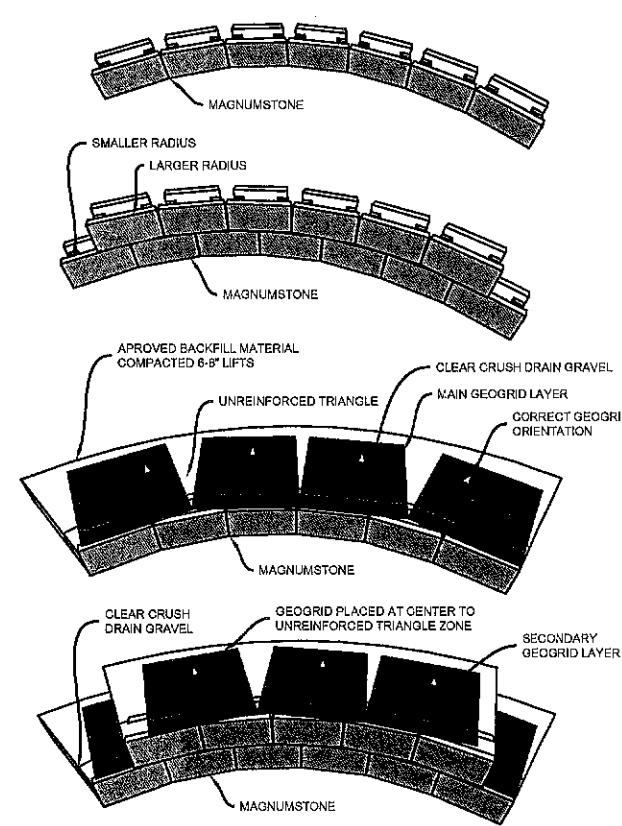

INSIDE CURVE

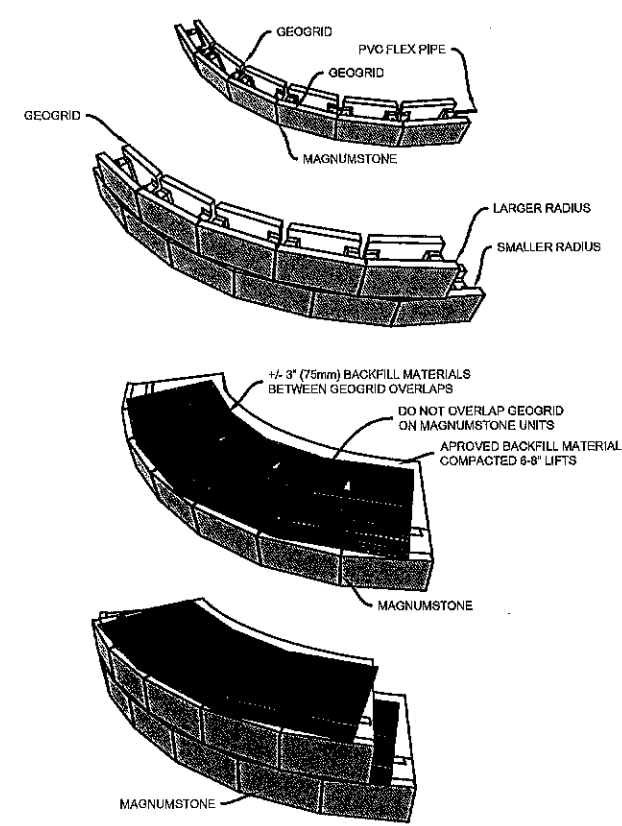

OUTSIDE CURVE

General Notes

No.	Revision/Issue	Date

MagnumStone™
by CORNERSTONE®

Project Name and Address

Project	Sheet
Date	
Scale	