

- Notes:
1. Drawing Shown With Concrete Lids, Concrete Risers and PVC Lids and Risers Available.
 2. Reinforcement Drawings Available Upon Request.
 3. Tank Designs Meet ASTM C1227, C890 & Montana DEQ Circular 4 With 6 Feet Of Bury.
 4. Traffic Rated Tank Lids Available.
 5. Pump Installation Available
 6. Minimum 4000 PSI Concrete

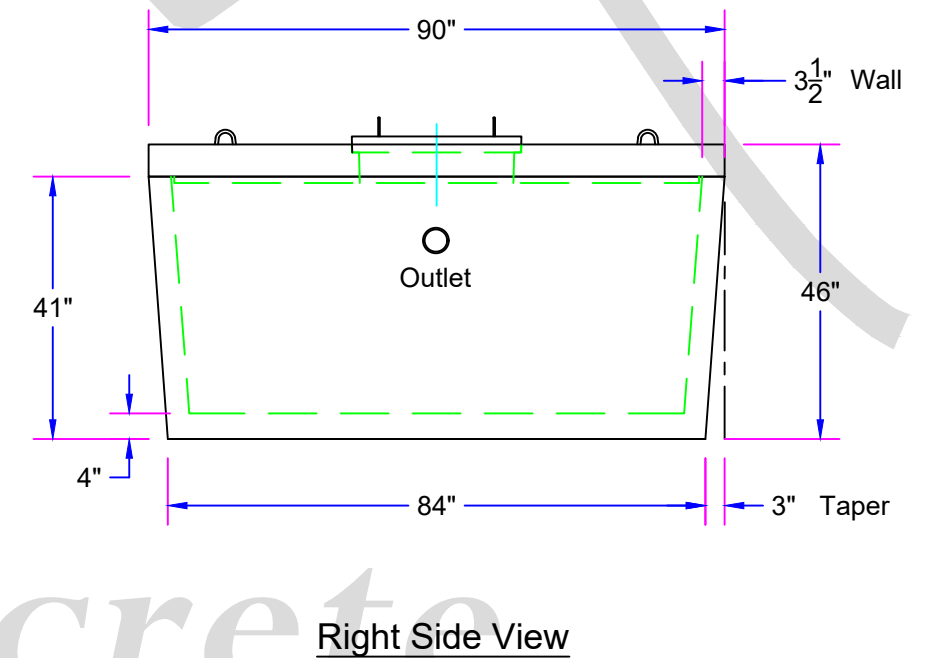

Approx. Weight With Standard Lid = **19,075 Lbs.**
 Approx. Weight With Traffic Rated Lid = **23,590 Lbs.**

Glacier
Precast
Concrete, Inc.

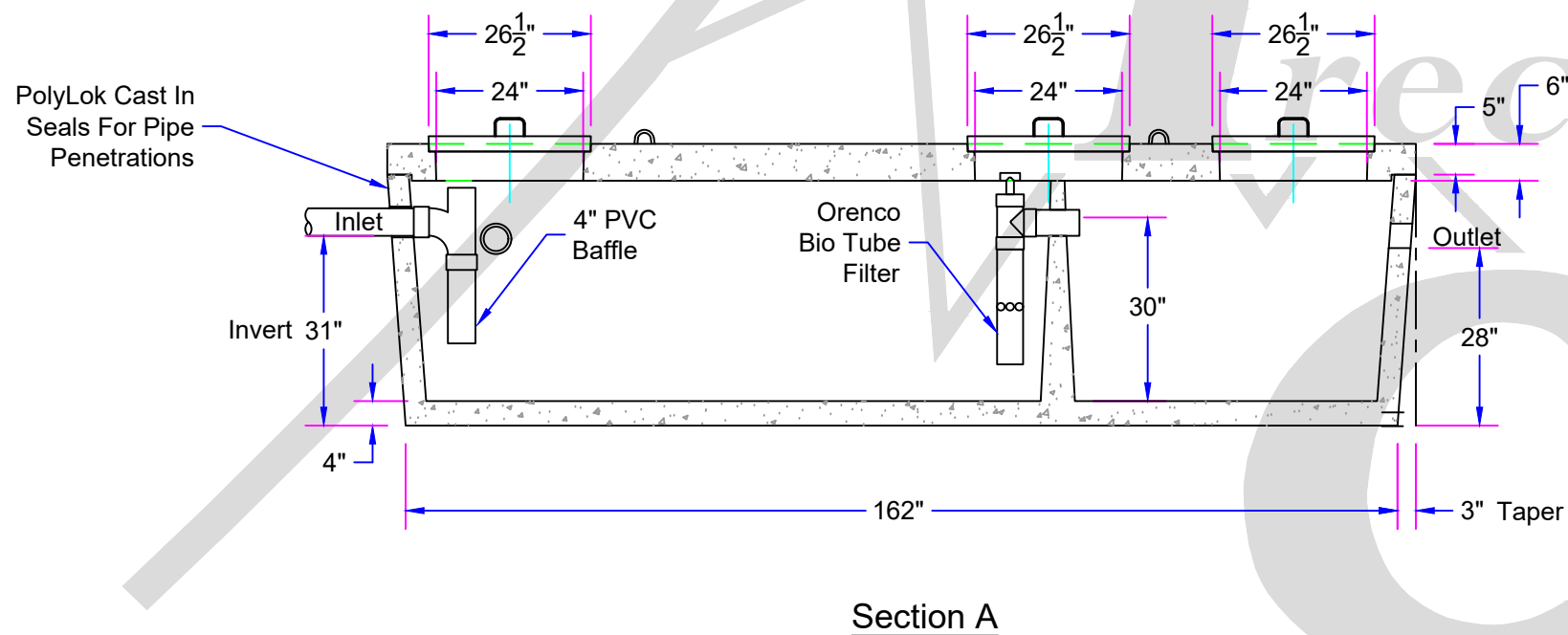

175 Alder Lane
Kalispell, MT. 59901
(406) 752-7163
www.glacierprecast.com
Or Visit Us On Facebook

AMENDMENTS:			
REV.	DESCRIPTION:	BY:	DATE:

SITE:	Glacier Precast Concrete
TITLE:	1000/500 Gallon Shallow Pump Chamber

DRAWING NO.	1:30	PROJECT NO.	11/29/2016
SCALE AT A4.	JRC	DATE.	3/8/24
DRAWN.	CHECKED.	REVISION.	