

- Notes:
1. No Inlets or outlets w/24" PRTA. Waterproof Tank
  2. Reinforcement Drawings Available Upon Request.
  3. Tank Designs Meet ASTM C1227, C890 & Montana DEQ Circular 4 With 6 Feet Of Bury.
  4. Traffic Rated Tank Lids Available.
  5. Pump Installation Available
  6. Minimum 4000 PSI Concrete w/ min 15 lbs/yd3 of Helix 5-25. Rebar wet set at tops

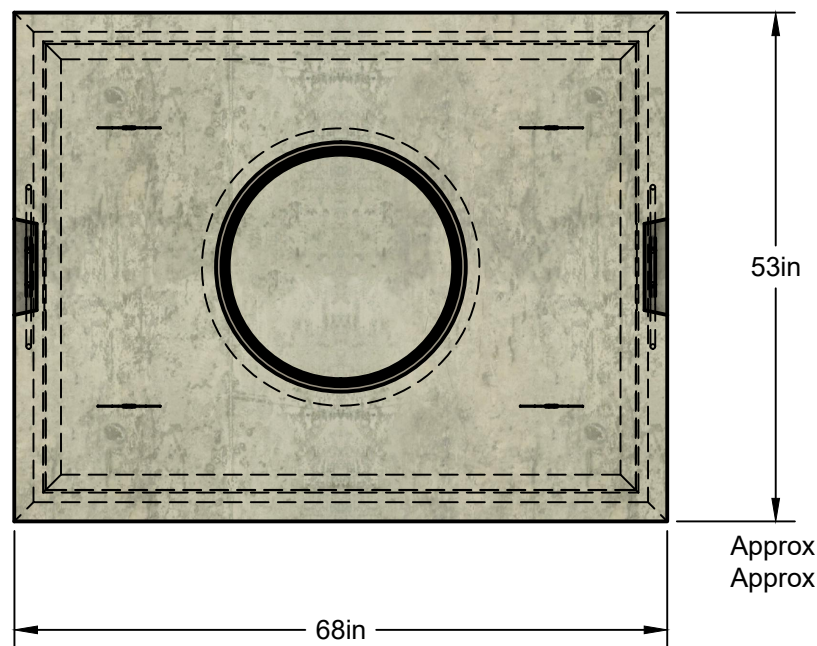

Approx. Weight With Standard Lid =5,990 Lbs.  
 Approx. Weight With Traffic Rated Lid =7,224 Lbs.

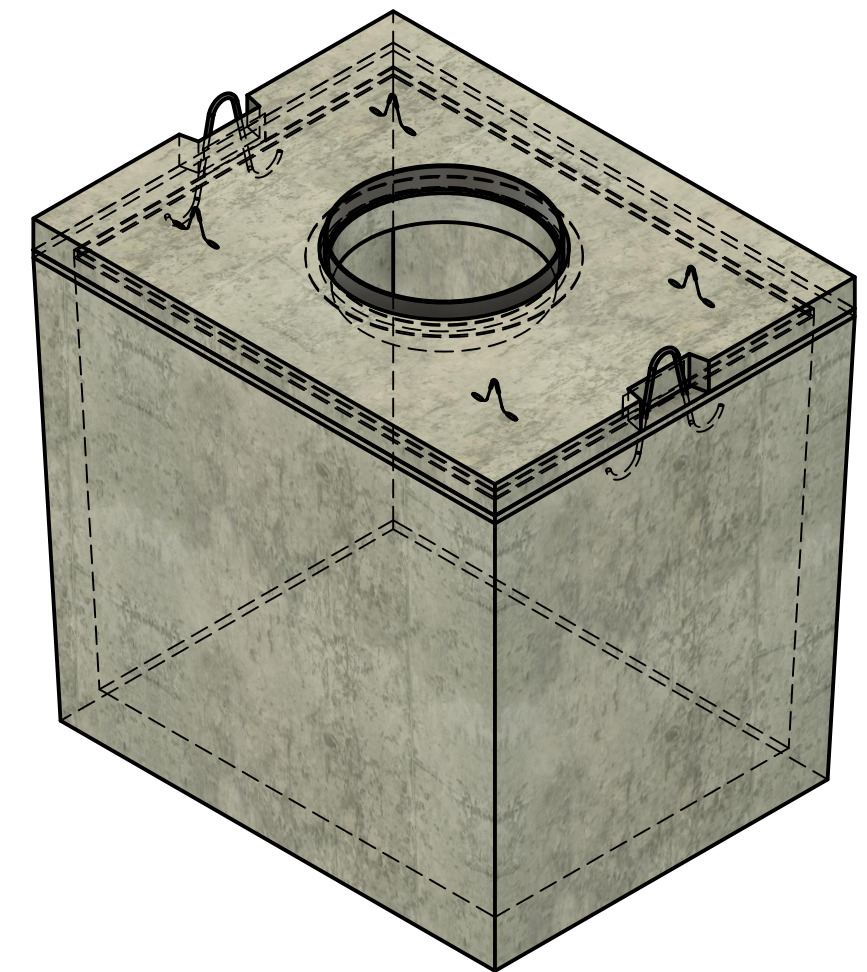

	COMPANY: GLACIER PRECAST CONCRETE		CUSTOMER: Glacier Precast Concrete			MIX: MH 4000 + 300L	QUANTITY:
	TITLE: 500 Gallon Advantex		PROJECT NAME:			CY: 1.5 CY	SCALE: 1:20
	DRAWN BY: EP	DATE DRAWN: 03/11/2024	PM:	RELEASED FOR PROD.:	APPROX. DELIVERY:	WEIGHT: 5,990 lbs	SHEET: 1/1

